

### Features

- Low conduction loss due to low  $V_F$
- Extremely low switching loss by tiny  $Q_C$
- Highly rugged due to better surge current
- Industrial standard quality and reliability

HF

### Applications

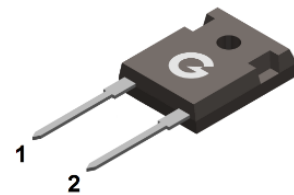
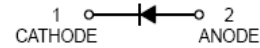
- UPS
- Power Inverter
- High performance SMPS
- Power factor correction

### Mechanical Data

- Case: TO-247-2L
- Molding compound: UL flammability classification rating 94V-0
- Terminals: Tin-plated; solderability per MIL-STD-202, Method 208

### Key performance parameters

Type	GSC2D40120U
$V_{DC}$	1200V
$I_F @ 158^\circ\text{C}$	40A
$Q_C @ 400\text{V}$	150nC
$T_J$	175°C



TO-247-2L

### Ordering Information

Part Number	Package	Shipping Quantity	Marking Code
GSC2D40120U	TO-247-2L	30 pcs / Tube	GSC2D40120U

### Maximum Ratings (@ $T_C = 25^\circ\text{C}$ unless otherwise specified)

Parameter	Symbol	Value	Unit
Peak Repetitive Reverse Voltage	$V_{RRM}$	1200	V
Surge Peak Reverse Voltage	$V_{RSM}$	1200	V
DC Peak Reverse Voltage	$V_R$	1200	V
Continuous Forward Current ( $T_C = 25^\circ\text{C}$ )	$I_F$	130	A
Continuous Forward Current ( $T_C = 135^\circ\text{C}$ )	$I_F$	67	A
Continuous Forward Current ( $T_C = 158^\circ\text{C}$ )	$I_F$	40	A
Non-Repetitive Forward Surge Current (10ms single half sine-wave, $T_C = 25^\circ\text{C}$ )	$I_{FSM}$	300	A
Non-Repetitive Forward Surge Current (10ms single half sine-wave, $T_C = 110^\circ\text{C}$ )		258	A
Repetitive Peak Forward Surge Current (10ms half sine-wave, $T_C = 25^\circ\text{C}$ )	$I_{FRM}$	160	A
Repetitive Peak Forward Surge Current (10ms half sine-wave, $T_C = 110^\circ\text{C}$ )		120	A
$i^2dt$ value (10ms single half sine-wave, $T_C = 25^\circ\text{C}$ )	$\int i^2 dt$	450	$\text{A}^2\text{s}$
$i^2dt$ value (10ms single half sine-wave, $T_C = 110^\circ\text{C}$ )		332	$\text{A}^2\text{s}$

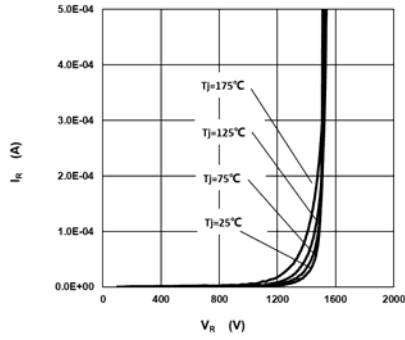
## Thermal Characteristics

Parameter	Symbol	Value	Unit
Power Dissipation ( $T_C = 25^\circ\text{C}$ )	$P_D$	600	W
Power Dissipation ( $T_C = 110^\circ\text{C}$ )		260	
Thermal Resistance Junction-to-Case	$R_{\theta JC}$	0.25	$^\circ\text{C/W}$
Operating junction Temperature	$T_J$	-55 ~ +175	$^\circ\text{C}$
Storage Temperature Range	$T_{STG}$	-55 ~ +150	$^\circ\text{C}$

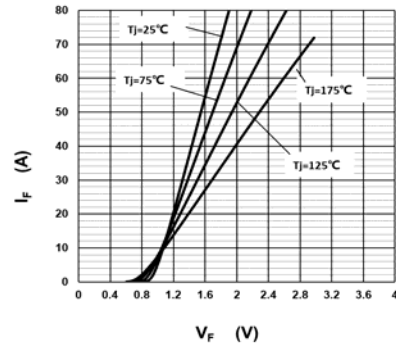
## Electrical Characteristics (@ $T_J = 25^\circ\text{C}$ unless otherwise specified)

Parameter	Symbol	Test Condition	Min.	Typ.	Max.	Unit
Forward Voltage	$V_F$	$I_F = 40\text{A}, T_J = 25^\circ\text{C}$	-	1.4	1.7	V
		$I_F = 40\text{A}, T_J = 175^\circ\text{C}$	-	2.0	-	V
Maximum Peak Reverse Current	$I_R$	$V_R = 1200\text{V}, T_J = 25^\circ\text{C}$	-	-	300	$\mu\text{A}$
		$V_R = 1200\text{V}, T_J = 175^\circ\text{C}$	-	-	500	$\mu\text{A}$
Total Capacitive Charge	$Q_C$	$V_R = 800\text{V}, di/dt = 100\text{A}/\mu\text{s}$	-	190	-	nC
Total Capacitance	$C_J$	$V_R = 0\text{V}, f = 1\text{MHz}$	-	2694	-	pF
		$V_R = 400\text{V}, f = 1\text{MHz}$	-	187	-	
		$V_R = 800\text{V}, f = 1\text{MHz}$	-	145	-	

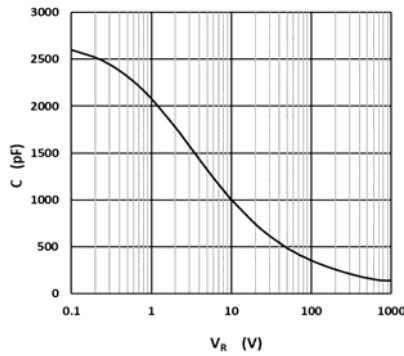
**Ratings and Characteristics Curves** (@  $T_A = 25^\circ\text{C}$  unless otherwise specified)



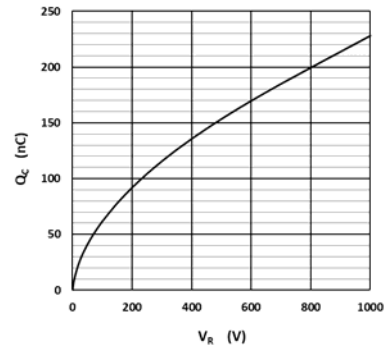
**Fig 1 Typical Reverse Characteristic**



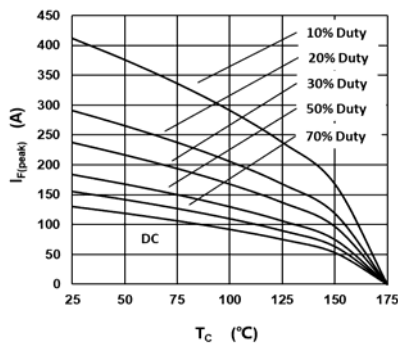
**Fig 2 Typical Forward Characteristics**



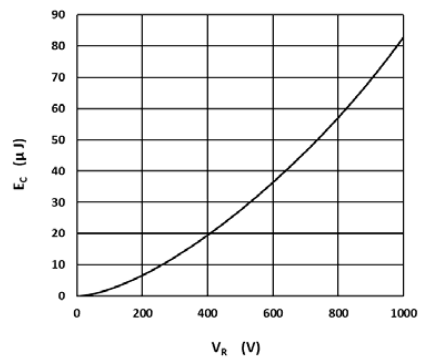
**Fig 3 Capacitance vs. Reverse Voltage**



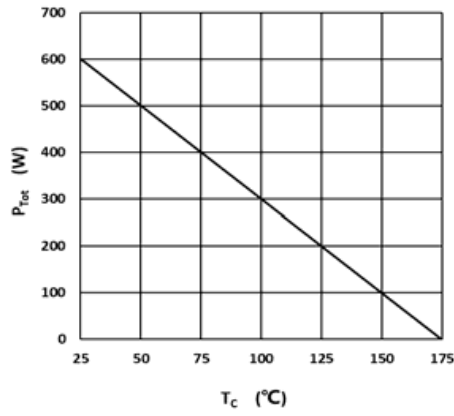
**Fig 4 Reverse Charge vs. Reverse Voltage**



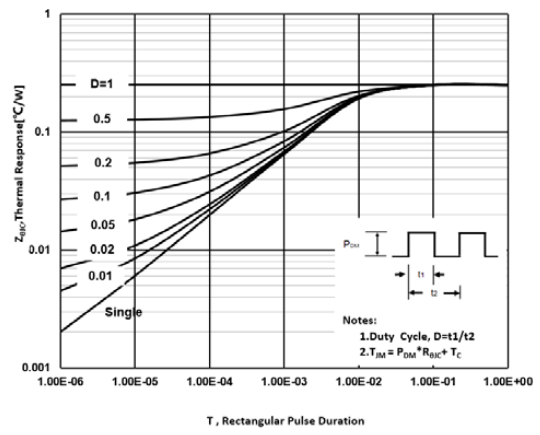
**Fig 5 Current Derating**



**Fig 6 Typical Capacitance Stored Energy**

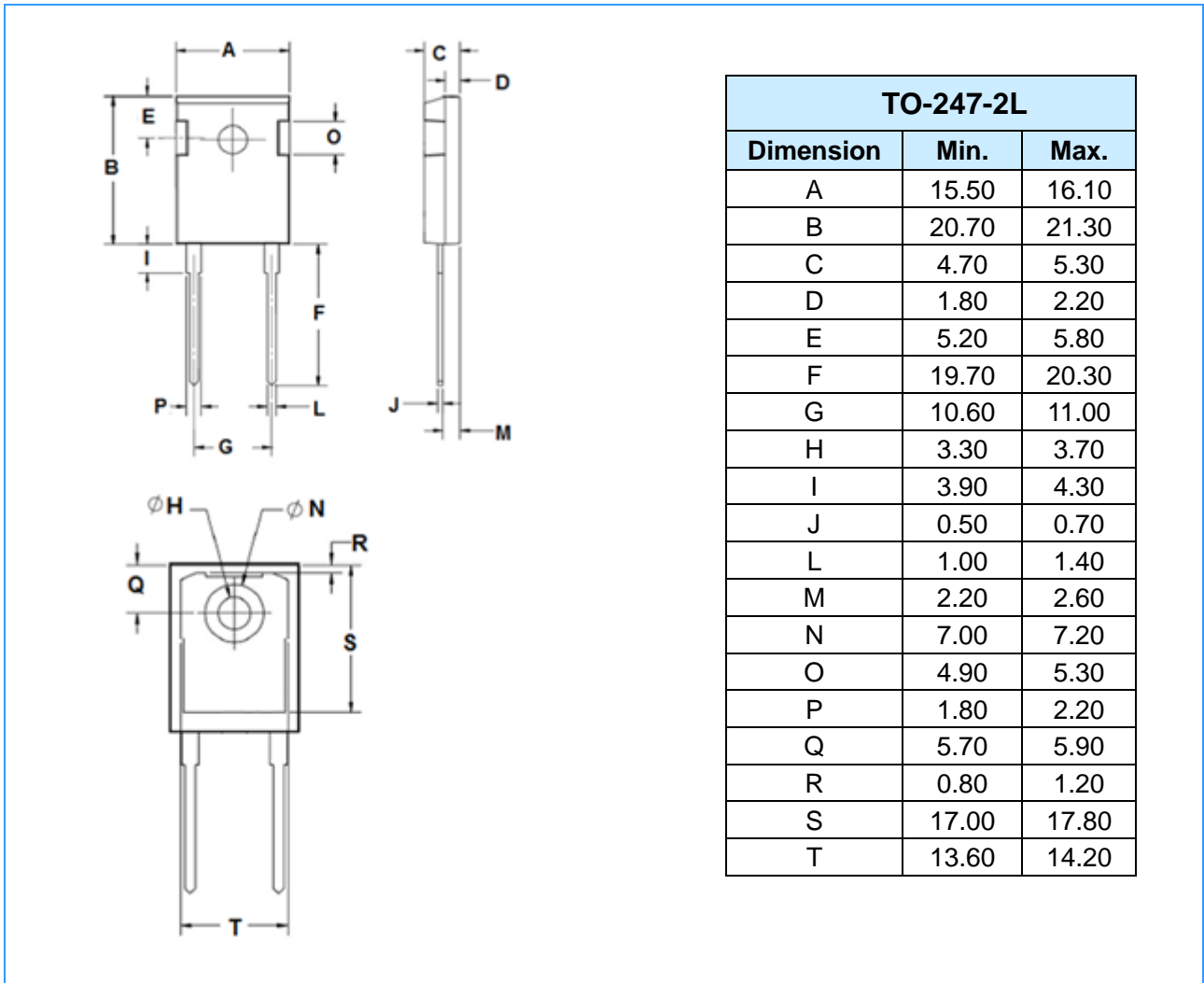


**Fig 7 Power Derating**



**Fig 8 Transient Thermal Impandance**

**Package Outline Dimensions** (Unit: mm)



**IMPORTANT NOTICE**

Changzhou Galaxy Century Microelectronics (GME) reserves the right to make changes without further notice to any product information (copyrighted) herein to make corrections, modifications, improvements, or other changes. GME does not assume any liability arising out of the application or use of any product described herein; neither does it convey any license under its patent rights, nor the rights of others.